



# **OPERATION & MAINTENANCE MANUAL**

**For**

## **VIL VERTICAL INLINE PUMPS Types CS, CC, RC, and DS**

**PATTERSON PUMP COMPANY  
A GORMAN-RUPP COMPANY  
PO Box 790  
2129 Ayersville Road  
Toccoa, Georgia 30577 USA  
Telephone: 706-886-2101**

Revision 9

## **SAFETY PRECAUTIONS**

### **WARNING**

Do not operate this equipment in excess of its rated speed or other than in accordance with the instructions contained in this manual.

The equipment has been found satisfactory of the conditions for which it was sold, but its operation in excess of these conditions may subject it to stresses and strains which it was not designed to withstand.

For equipment covered by this instruction book, it is important to observe safety precautions to protect personnel from possible injury. Among the many considerations, personnel should be instructed to:

- avoid contact with rotating parts
- avoid bypassing or rendering inoperative any safeguards or protective devices
- avoid extended exposure in close proximity to machinery with high noise levels
- use proper care and procedures in handling, lifting, installing, operating and maintaining the equipment
- do not modify this equipment – consult factory if modification is deemed necessary
- do not substitute for repair parts which can be provided by the equipment manufacturer.

Safe maintenance practices with qualified personnel are imperative.

Failure to heed this warning may result in an accident causing personal injury.

# TABLE OF CONTENTS

<b>SECTION I:</b>	<b>General Information</b> .....	1
<b>SECTION II:</b>	<b>Storage &amp; Protection</b>	
	2-1 Storage & Protection.....	1
	2-2 Uncrating.....	2
	2-3 Handling VIL-RC & VIL-DS Units Shipped Horizontally .....	2
<b>SECTION III:</b>	<b>Installation</b>	
	3-1 Location .....	3
	3-2 Mounting .....	3
	3-3 Piping.....	3
	3-4 Wiring and Controls .....	4
<b>SECTION IV:</b>	<b>Operation</b>	
	4-1 Starting.....	4
	4-2 Shutdown .....	5
<b>SECTION V:</b>	<b>Maintenance</b> .....	6
<b>SECTION VI:</b>	<b>Repairs &amp; Replacement</b>	
	6-1 Disassembly .....	7
	6-2 Cleaning.....	7
	6-3 Inspection.....	8
	6-4 Assembly .....	8
	Types CS & CC.....	8
	Type RC.....	9
	Type DS.....	10
	<b>Locating Operation Difficulties</b> .....	12
	<b>Recommended Spare Parts</b> .....	14
	<b>Typical Assembly Sections</b> .....	15, 16, 17, 18, 19
	<b>Shaft Collar Settings, Type VIL-RC, motor frames 286 &amp; smaller</b> ....	20
	<b>Notes</b> .....	21

## **SECTION I**

### **GENERAL INFORMATION**

This manual covers the installation, operation and maintenance of Patterson Pump vertical inline pumps. The pump is a centrifugal, single stage close-coupled type. When properly installed and when given reasonable care and maintenance, centrifugal pumps should operate satisfactorily for a long period of time. Centrifugal pumps use the centrifugal force principal of accelerating the liquid within a rotating impeller, and then collecting it and converting it to pressure head in a stationary volute.

The pump consists of two assemblies:

1. Volute assembly or stationary part
2. Rotating element or moving part

The back pullout design casing allows removal of the impeller and rotating element without disturbing suction and discharge piping. The suction and discharge flanges are on a common centerline 180 degrees apart. Suction and discharge flanges are drilled and tapped for gauge connections. The volute is drilled and tapped on the underside for complete pump drain. Casing wear rings are provided as standard equipment.

## **SECTION II**

### **2-1 STORAGE & PROTECTION**

All pumps are shop serviced and ready for operation when delivered, but there are occasions when considerable time elapses between the delivery date and the time the pump is put into operation. Equipment which is not in service should be kept in a clean, dry area. If equipment is to be stored for long periods of time (six months or more), the following precautions should be taken to insure that the equipment remains in good condition.

1. Unpainted-machined surfaces, which are subject to corrosion, should be protected by some corrosive resistant coating.
2. The shaft should be rotated 10 to 15 revolutions by hand periodically in order to spread the lubricant over all the bearing surfaces. Suitable intervals are from one to three months, depending on atmospheric conditions, etc. In order to insure that the pump shaft does not begin to sag, do not leave the shaft in the same position each time.
3. Space heaters on motors and controllers should be connected and fully operable if atmospheric conditions approach those experienced in operation. Consult instruction manuals for other precautions concerning storage of individual components of pumping unit.
4. Fresh lubricant should be applied to bearings upon removal of equipment from storage. Refer to motor manual.

## 2-2 Uncrating

Vertical HVAC In-Line pumps are thoroughly inspected before shipment to assure they meet with your order requirements. After removing the pump from the crate, make sure the equipment is in good order and that all components are received as called for on the packing list. **(ANY SHORTAGES OR DAMAGE SHOULD BE REPORTED IMMEDIATELY.)**

Use extreme care in handling the unit, placing slings and hooks carefully so that harmful stresses will not be imposed on the pump.

**NEVER PLACE CABLE SLINGS AROUND THE PUMP SHAFT. THE EYE BOLTS OR LIFTING LUGS ON THE MOTOR ARE INTENDED FOR LIFTING ONLY THE MOTOR AND NOT THE COMPLETE UNIT.**

## 2-3 Handling VIL-RC and VIL-DS units shipped horizontally

An effective way of lifting a unit from the shipment pallet following uncovering the unit is to place lifting hooks through the motor lifting lugs or straps around the upper part of the motor, taking care to secure the lifting devices in such a way that they will not come loose as the unit is handled.

Carefully lift sufficiently to stand the unit in a vertical position. Lift the unit only far enough to remove the pallet from underneath then lower it gently onto a flat surface. Be sure pump unit is stable and secure and it will not tip over.

Remove the coupling guard and place (2) lifting straps through the pump/motor pedestal, one on each side of the motor shaft and secure to the lifting device. With the straps in place, using a spacer bar if necessary to protect the motor fan cover, the whole assembly can now be lifted securely and placed in position in the piping.

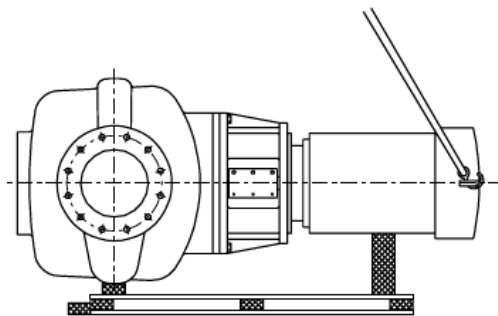

Secure pallet and lift unit to the vertical position using motor eye-bolts.  
Take care to secure the lifting devices in such a way that they will not come loose.  
Then lift high enough only to clear pallet, and gently place on a flat floor surface in a stable upright position.

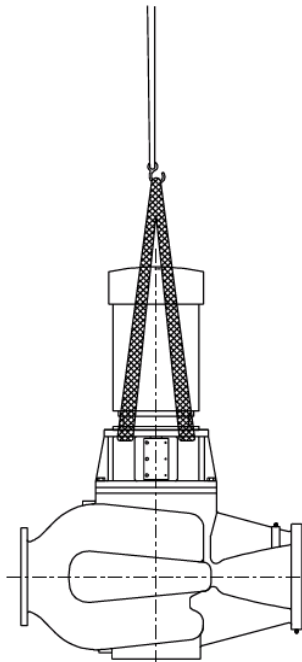

Remove the coupling guard, place lifting straps through the pump/motor pedestal. With the straps in place, the whole assembly can now be lifted and placed in position in the piping.

### **SECTION III**

#### **INSTALLATION**

##### **3-1 Location:**

Several factors should be considered when selecting a location for the pumping. The unit should be accessible for both inspection and maintenance. Headroom should be provided for the use of crane, hoist or other necessary lifting devices. The pump should be located as close as possible to the liquid supply so that the suction line is short and direct. Location should require a minimum of elbows and fittings in the discharge line to minimize friction losses. The unit should be protected against flooding.

##### **3-2 Mounting:**

The pump unit is designed to be installed in the pipeline. Standard piping supports on either side of the pump should be used to eliminate pipe stresses. When use grouting the base is recommended.

##### **3-3 Piping:**

The suction and discharge pipes must be in line, and the pump must not be used to pull the piping into place by tightening the flange bolts. Pipes should be supported near the pump.

### 3-4 Wiring and Controls:

The electric motor power supply connections must conform to national and local codes. The motor ratings stamped on the motor nameplate must match the line voltage and wire capacity. **DO NOT USE ANY OTHER VOLTAGE**

## SECTION IV

### OPERATION

#### **CAUTION:**

Do not exceed the rated working pressure of the pump.

The sum of the suction pressure and the maximum pump operating head (converted to units of pressure) must be less than the pump working pressure, at all times.

#### **CAUTION:**

Do not exceed the pressure capabilities of the mechanical seals.

The maximum pressure on the mechanical seal for this pump type is equal to the suction pressure plus 10% of the maximum pump operating head (converted to units of pressure) for a new pump.

For a pump with worn internal ring clearance, the maximum pressure on the mechanical seal is equal to the suction pressure plus 15% of the maximum pump operating head (converted to units of pressure).

This pressure must not exceed the rated working pressure of the mechanical seals.

#### 4-1 Starting:

- Turn the pump shaft by hand to insure that the parts do not bind
- Open the valve in the pump suction line, if fitted
- Close discharge valve
- Prime the pump in one of the following ways:
  1. If the pump operates under positive pressure, open vent valve on top of the pump casing. After all entrained air has escaped, close the vent valves. Rotate the shaft, if possible, to allow any air trapped in the impeller passages to escape.
  2. If the pump operates on a suction lift and a foot valve is included in the system, fill the pump and the suction line with liquid from an outside source. Trapped air should be allowed to escape through the vent valve while filling.

3. If the pump operates on a suction lift and no foot valve is provided, use a vacuum pump or ejector operated by air, steam, water, etc. to evacuate air from the pump case and suction line by connecting the ejector to the priming connection on top of the pump case.
- Check direction of rotation before starting pump. Rotation should be the same as the direction arrow on the case.

**CAUTION:**

- Do not operate without liquid. Pump seals depend on the liquid being pumped for lubrication.
- Make sure pump is primed and that no air is in the suction piping and the pump case.
- Make sure all valves open or closed as required by your specific requirements.

**Start driver:**

Open discharge valve slowly when the pump is up to speed.

**CAUTION:**

Overheating and/or loss of prime will result if the pump is operated against a closed valve for more than a few minutes.

**NOTE:** Should the pump fail to build up pressure or discharge water when the discharge valve is opened, stop the pump and read **Section Locating Operating Difficulties**.

**4-2 Shutdown:**

The pump may be stopped with the discharge valve open without causing damage. However, in order to prevent water hammer effects, as a general recommendation the discharge valve should be closed first.

1. Close discharge valve.
2. Stop driver.
3. If danger of freezing exists, isolate the pump by closing a valve in the pump suction line, if fitted, and drain the pump completely



## SECTION V

### MAINTENANCE

1. There should be no mechanical seal leakage except for a brief break in period. Mechanical seals should be replaced if they are leaking
3. **Refer to the motor manufacturer's instructions for periodic maintenance requirements.**
4. Check that electrical control equipment contacts are in good condition and clean.
5. Bearing relubrication requirements – refer to the motor manufacturer's instructions. Do not overlubricate the bearings.. Such action will cause bearings to overheat.
6. Refer to the “**General Pump Inspection and Maintenance Schedule**” for best results.

### General Pump Inspection and Maintenance Schedule VIL Pumps, Types CS, CC, RC, and DS

**Excludes motors, VFD's, and controls.**

Contact Patterson Pump Company if assistance is needed to determine the inspection and service requirements for a specific pump.

Inspect (✓) or service (•) at the indicated calendar time or run time interval – whichever comes first	Routinely	Monthly	2000 hours or 3 months	4000 hours or 6 months	8000 hours or 12 months
Unusual noise	✓				
Unusual vibration	✓				
Unusual temperature	✓				
Leaks in pump or piping	✓				
Pressure gauge readings	✓				
Visual inspection of equipment general condition	✓				
Anytime a pump is opened, inspect the running clearances and restore them to original specifications if the running clearances have doubled.	✓ •				
Anytime a pump is opened, inspect the impeller for corrosion or excessive wear.	✓ •				
Mechanical seal (should be no leakage)	✓				
Drain lines are working properly	✓				
Coupling integrity (Type RC only)	✓				
Operate the pump		✓			
Add grease to motor anti-friction bearings (maintain records)	Refer to motor manufacturer's instructions.				
Perform a comparative field test (flow, pressures, and power) with calibrated instruments. Restore internal running clearances if results are unsatisfactory (install new wear rings).					✓ •
Perform a comparative vibration test					✓
Inspect sleeve. Replace if worn.					✓ •

**SECTION VI**  
**REPAIRS AND REPLACEMENT**

**WARNING!!!**

Whenever any disassembly work is to be done on the pump, disconnect the power source to the driver to eliminate any possibility of starting unit. It is advisable that a qualified Pump service technician does the disassembly and reassembly of the pump.

**6-1 To Remove Impeller and Mechanical Seal**

Reference: Pump Assembly Section for the particular pump type

**Types CC and CS - To Remove Impeller and Mechanical Seal**

1. Remove bolting holding volute (1) to volute cover (11).
2. Pull motor and impeller assembly from the volute.
3. Remove impeller (2) from the motor shaft by turning the impeller screw (26) counterclockwise.
4. Mechanical seal (65) may now be removed.

**Type RC - To Remove Mechanical Seal**

1. Remove bolting holding rigid coupling (314) to motor shaft (10) and pump shaft (6).
2. Remove bolting holding gland (17) to volute cover (11).
3. Mechanical seal (65) may now be removed.

**Type RC - To Remove Impeller**

5. Remove bolting holding volute (1) to volute cover (11).
6. Pull motor and impeller assembly from the volute.
7. Remove impeller (2) from the motor shaft by turning the impeller screw (26) counterclockwise.

**6-2 Cleaning:**

**WARNING!!!**

Petroleum based cleaning solvents are flammable. Smoking or open flames in the vicinity of these solvents is extremely hazardous and must not be permitted. Disregarding this warning could result in grave personal injury.

Clean all metal parts with a solvent. Use a bristle brush (not metal or wire) to remove tightly adhering deposits. A fiber scraper may be used to remove the gasket and shellac from casing flange. Blow dry with clean dry compressed air.

### **CAUTION:**

**Never use hydrocarbon liquids (oil or solvent) to clean mechanical seal parts. Use of oil or solvent will deteriorate material used on the seal.**

**Use mild soap solution to clean seal parts. Use only your finger to remove dirt. Rinse with clean water and dry with mild air stream. Use care not to damage or scratch lapped surfaces.**

### **6-3 Inspection:**

Visually inspect parts for damage affecting serviceability. Check o-rings and gaskets for cracks, nicks, or tears; packing rings for excessive compression, fraying or shredding, and embedded particles. Replace if defective in any way. Mount shaft between lathe centers and check eccentricity for entire length of the shaft. Eccentricity should not exceed .002 inches (0.05 mm). Bearing surfaces should be smooth; shoulders square and free of nicks.

Measure OD of impeller hub and ID of pump casing. Compute diametrical clearance (ID minus OD) and compare with the original pump specifications. Surfaces must be smooth and concentric. Examine impeller passages for cracks, dents or embedded material. Examine shaft sleeves for wear

### **6-4 Assembly**

The following should prove helpful in reassembling the pump. Refer to the appropriate assembly drawing for the particular pump type.

#### **Assembly (Types CS and CC):**

1. All parts, inside and out, should be clean. Dirt and grit will cause excessive wear, plus needless shutdown.
2. Install pump shaft (6) and tighten set screws (Type CS only).
3. Install the deflector (40) onto the shaft (6).
4. Press the mechanical seal (65) into the volute cover (11).
5. Install the volute cover (11) onto the motor (19).
6. Lubricate the O.D. of the shaft sleeve (14) and the I.D. of the opposite half of the mechanical seal using **International Products P-80 Emulsion Temporary Assembly Lubricant** or equivalent (available from International Products Corporation, 201 Connecticut Dr, Burlington NJ 08016 USA, phone 609-386-8770, Fax 609-386-8438, <http://www.ipcol.com>, [mkt@ipcol.com](mailto:mkt@ipcol.com)). Press the shaft sleeve (14) through the seal. Coat the interior of the shaft sleeve (14) with **Dow Corning 732 Multi Purpose Sealant** or equivalent.
7. Press the shaft sleeve (14) onto the shaft (6) and install seal spring.
8. Insert the impeller key (32) into the shaft (6) keyway. Install the impeller (2) onto the shaft (6).
9. For type VIL-CS coat the impeller threads with **Loctite 262 Threadlocker** or equivalent. Install the impeller. For type VIL-CC coat the impeller bolt (26) with **Loctite 262 Threadlocker** or equivalent. Install the impeller washer (24) and bolt (26).

10. Install the casing ring (7) into the casing (1).
11. Install the gasket (73) and position the rotating assembly into the casing (1).
12. Install and tighten casing bolts.
13. Install all NPT fittings and tubing.
14. Rotate by hand when possible to insure that the parts do not bind.

**Assembly (Type RC):**

1. Install Casing Ring (7).
2. Insert the shaft (6) into the impeller (2). Coat impeller bolt (26) with **Loctite 262 Threadlocker** or equivalent. Assemble with washer (69), key (32) and bolt (26).
3. Install the throttle bushing (39) into the volute cover \ motor stand (11).
4. Place the casing gasket onto the casing (1).
5. Lower the motor stand \ volute cover (11) down onto the casing (1).
6. Press the mechanical seal face into the gland (17).
7. Install the mechanical seal retaining ring on to the shaft (6).
8. Lubricate the interior of the mechanical seal using **International Products P-80 Emulsion Temporary Assembly Lubricant** or equivalent (available from International Products Corporation, 201 Connecticut Dr, Burlington NJ 08016 USA, phone 609-386-8770, Fax 609-386-8438, <http://www.ipcol.com>, [mkt@ipcol.com](mailto:mkt@ipcol.com)) and install onto the shaft (6).
9. Install the gland gasket and gland (17).
10. Install and tighten casing bolts.
11. Bolt the motor (19) onto the motor stand (11) with the conduit box in the proper orientation.
12. Verify the shaft parallel alignment as follows:  
Mount a magnetic base dial indicator on the motor shaft with the indicator on the pump shaft O.D., as described in the following figure.

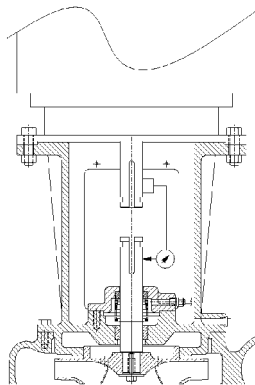

Rotate the motor shaft gently with care to apply the force needed to rotate the shaft as far from the dial indicator as possible so as to avoid a false indication. Verify the shafts have no more than 0.002" (0.05 mm) parallel misalignment. If more is indicated, the pump shaft is able to shift a small amount. Shift by hand (so as to not damage the mechanical seal) as required to align the shafts.

13. Place the collars (72A and 72B) onto the shafts. (NOTE: For VIL-RC pumps with motor frames 286 and smaller, a solid collar is used on the motor shaft that has a specific location setting on the motor shaft. Refer to the table provided at the end of this manual for the proper setting.)
14. Place the keyed half of the coupling (314) onto the pump shaft, with the motor and pump shaft keys oriented 180 degrees from the work area, for convenience. Use a wood block and pry bar to raise the rotating element up approximately 1/4" (6 mm) to allow the coupling (314) to fit with the collar on the motor shaft (10).
15. Hold the other coupling half (314) in place and install coupling screws, only hand-tight at this time. NOTE! Coupling halves are match-marked. Assemble coupling halves as indicated by the match-marks.
16. Tighten the coupling screws in the sequence described in the following figure, taking care to maintain an equal and parallel gap between the coupling halves on both sides for either the six screw or eight screw coupling type shown, as applicable. Use a feeler gauge to measure the gaps on each side of the coupling to verify that equal and parallel gaps between the coupling halves has been obtained. DO NOT pull one side of the split coupling tighter to have a smaller gap on one side!

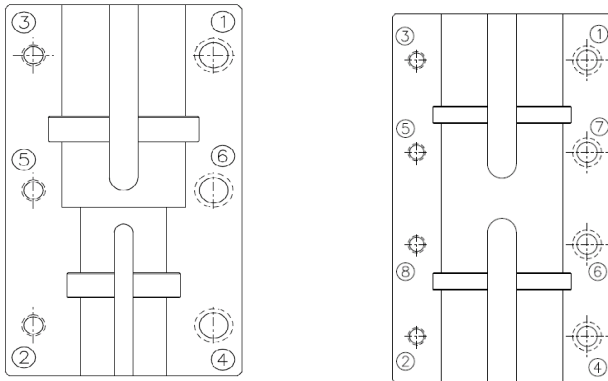

17. Install all NPT fittings and tubing.
18. Rotate by hand to insure that the parts do not bind.

**Assembly (Type DS):**

1. Install the lower bushing (72) into the casing (1).
2. Install lower casing ring (7).
3. Insert the shaft (6) into the impeller (2). Assemble with key (32) and impeller nut (24) Tighten the locking screws in the impeller nut (24).
4. Install the throttle bushing (39) into the volute cover (11).
5. Install the upper casing ring (7) into the volute cover (11).

6. Install one O-ring onto the periphery of the lower end of the volute cover (11) and install one O-ring onto the periphery of the volute cover (11) and adjacent to the shoulder near the top of the volute cover (11). Lubricate using **International Products P-80 Emulsion Temporary Assembly Lubricant** or equivalent (available from International Products Corporation, 201 Connecticut Dr, Burlington NJ 08016 USA, phone 609-386-8770, Fax 609-386-8438, <http://www.ipcol.com>, [mkt@ipcol.com](mailto:mkt@ipcol.com))..
7. Lower the volute cover\rotating assembly down into the casing (1). **Note: Align the cast notches in the casing (1) and volute cover (11).**
8. Press the seal face into the gland (17).
9. Install the mechanical seal retaining ring onto the shaft (6).
10. Lubricate the interior of the mechanical seal (65) using **International Products P-80 Emulsion Temporary Assembly Lubricant** or equivalent and install onto the shaft (6).
11. Install the gland gasket and gland (17).
12. Place the motor stand onto the volute cover (11) with the openings toward the suction and discharge flanges.
13. Install and tighten casing bolts.
14. Bolt the motor (19) onto the motor stand, with the conduit box properly oriented.
19. Verify the shaft parallel alignment as follows:  
Mount a magnetic base dial indicator on the motor shaft with the indicator on the pump shaft O.D., as described in the following figure.

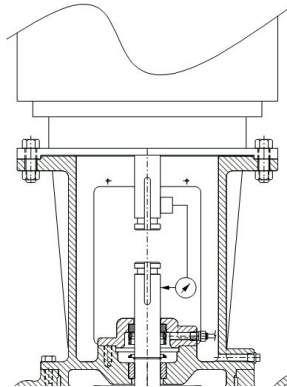

Rotate the motor shaft gently with care to apply the force needed to rotate the shaft as far from the dial indicator as possible so as to avoid a false indication.  
Verify the shafts have no more than 0.002" (0.05 mm) parallel misalignment.  
If more is indicated, the pump shaft is able to shift a small amount. Shift by hand (so as to not damage the mechanical seal) as required to align the shafts.

20. Place the collars (72A and 72B) onto the shafts.
21. Place the keyed half of the coupling (314) onto the pump shaft, with the motor and pump shaft keys oriented 180 degrees from the work area, for convenience. Use a wood block and pry bar to

raise the rotating element up approximately ¼" (6 mm) to allow the coupling (314) to fit with the collar on the motor shaft (10).

22. Hold the other coupling half (314) in place and install coupling screws, only hand-tight at this time. NOTE! Coupling halves are match-marked. Assemble coupling halves as indicated by the match-marks.
23. Tighten the coupling screws in the sequence described in the following figure, taking care to maintain an equal and parallel gap between the coupling halves on both sides for either the six screw or eight screw coupling type shown, as applicable. Use a feeler gauge to measure the gaps on each side of the coupling to verify that equal and parallel gaps between the coupling halves has been obtained. DO NOT pull one side of the split coupling tighter to have a smaller gap on one side!

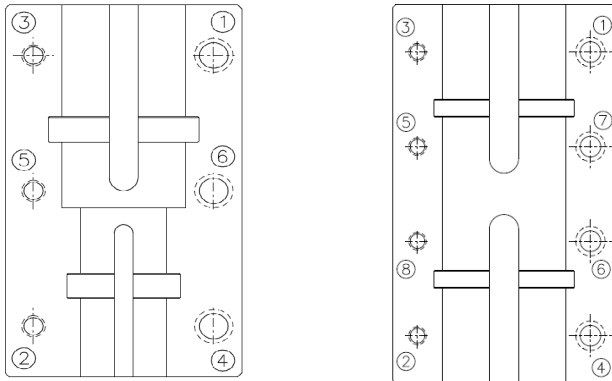

15. Install all NPT fittings and tubing.
16. Rotate by hand to insure that the parts do not bind.

### LOCATING OPERATING DIFFICULTIES

In the majority of cases, operating difficulties are external to the pump and the following causes should be carefully investigated before undertaking repairs:

#### No Water Delivered

- Pump not primed – indicated by no pressure on discharge.
- Speed too low – indicated by low pressure on discharge.
- Valve closed – indicated by high discharge head.
- Impeller completely plugged up – indicated by low discharge pressure.

#### Abnormally Small Quantities Delivered

- Air leaks in suction pipe or stuffing boxes.
- Speed too low.
- Discharge head higher than anticipated.

- Impeller partially plugged up.
- Obstruction in suction line.
- Mechanical defects: casing rings worn, impeller damaged, casing or seal defective.

#### **Insufficient Pressure**

- Speed too low. Might be caused by low voltage or current characteristics different from nameplate reading on the motor.
- Air in water will cause the pump to make a cracking noise.
- Mechanical defects: worn casing rings, damaged impeller, defective casing or seal.

#### **Intermittent Operation**

- Leaky suction line.
- Water seal plugged (hence, a leaky stuffing box).
- Suction lift too high.
- Air, gas or vapor in liquid.

#### **Pump Overloads Driver**

- Speed too high.
- Head lower than rated, hence, pumping too much water. (This is valid for low specific speed pumps).
- Mechanical defects: stuffing boxes too tight, shaft bent, rotating element binds.
- Rubbing due to foreign matter in the pump between the case ring and the impeller.

#### **Pump Vibrates**

- Misalignment.
- Foundation not sufficiently rigid.
- Impeller partially clogged.
- Mechanical defects: bent shaft, rotating element binds, bearings worn, coupling defective.
- Suction and discharge pipes not anchored.
- Pump cavitating from too high a suction lift.
- Air entrainment in the pump suction due to low submergence.



## RECOMMENDED SPARE PARTS FOR VIL PUMPS

Reference: Assembly Section for the Pump Type

### INTERMITTENT DUTY

Number	Description
7	Casing Ring
14	Shaft Sleeve (Type CC only)
65	Mechanical Seal
	Gasket (casing)
	O-rings (volute cover – Type DS)

### CONTINUOUS DUTY

Number	Description
2	Impeller
6	Shaft (Types RC and CS only)
7	Casing Ring
14	Shaft Sleeve (Type CC only)
26	Impeller Screw
39, 39A	Bushing (Types RC & DS)
39B	Lower Bushing (Type DS)
40	Deflector (Types CC and CS only)
65	Mechanical Seal
314	Coupling and bolts
72A, 72B	Collars
	All Hardware (not shown)
	Gasket (casing)
	O-rings (volute cover – Type DS)

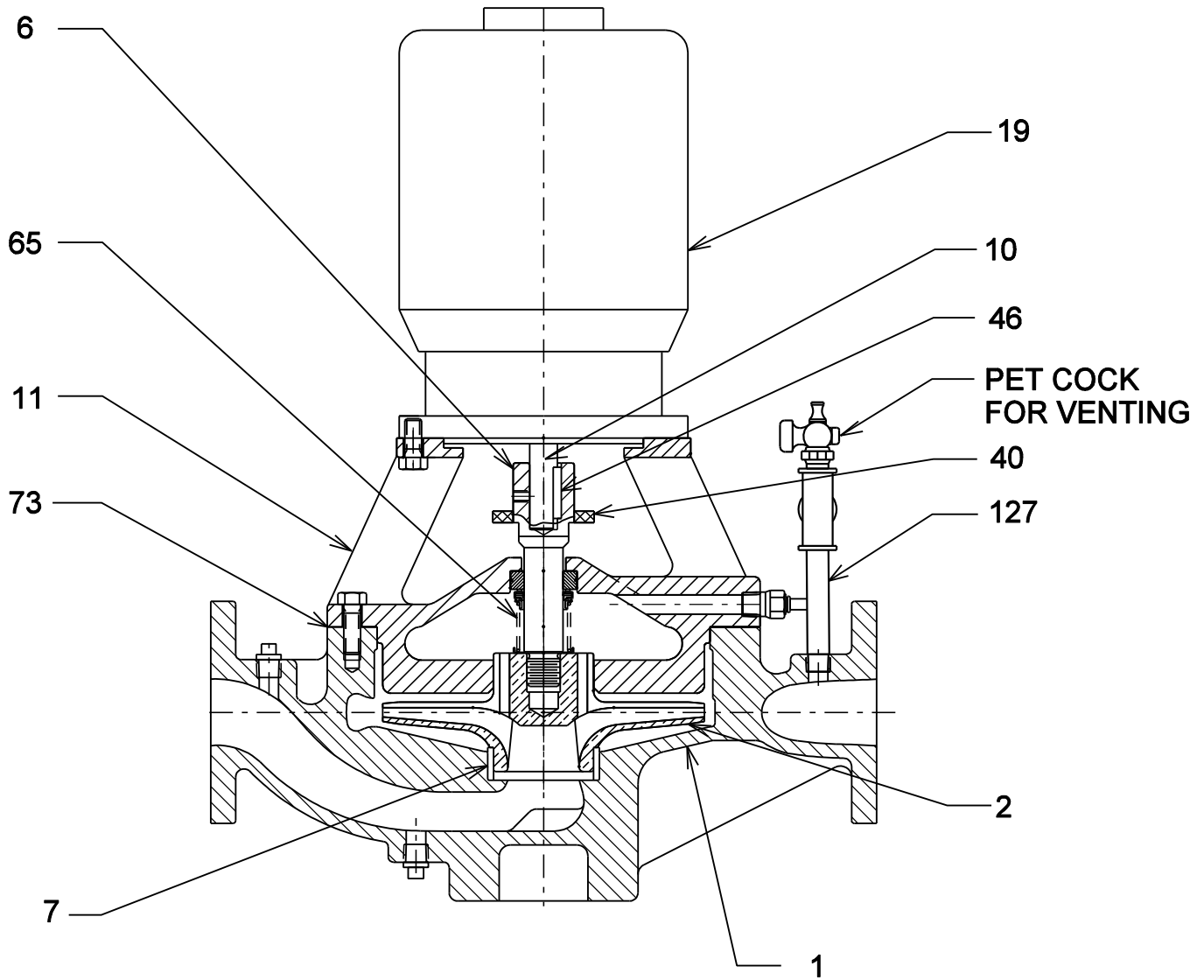

## Typical Assembly Section, Type VIL-CS

ITEM	DESCRIPTION	MATERIAL	ITEM	DESCRIPTION	MATERIAL
1	CASING	Cast Iron - ASTM A48-CL30	40	DEFLECTOR	Nitrile
2	IMPELLER	Bronze - ASTM B584-875	46	MOTOR KEY	Steel
6	PUMP SHAFT	416 S.S.	65	MECHANICAL SEAL	316 S.S. / Carbon VS. Silicon Carbide
7	CASING RING	Bronze - ASTM B505-932	65	MECHANICAL SEAL (OPTIONAL)	316 S.S. / Tungsten Carbide VS. Tungsten Carbide
10	MOTOR SHAFT	Steel	73	GASKET	VELLUMOID
11	VOLUTE COVER	Cast Iron - ASTM A48-CL30	127	WATER SEAL PIPING	BRONZE / RUBBER
19	MOTOR	Mfg. Std.			

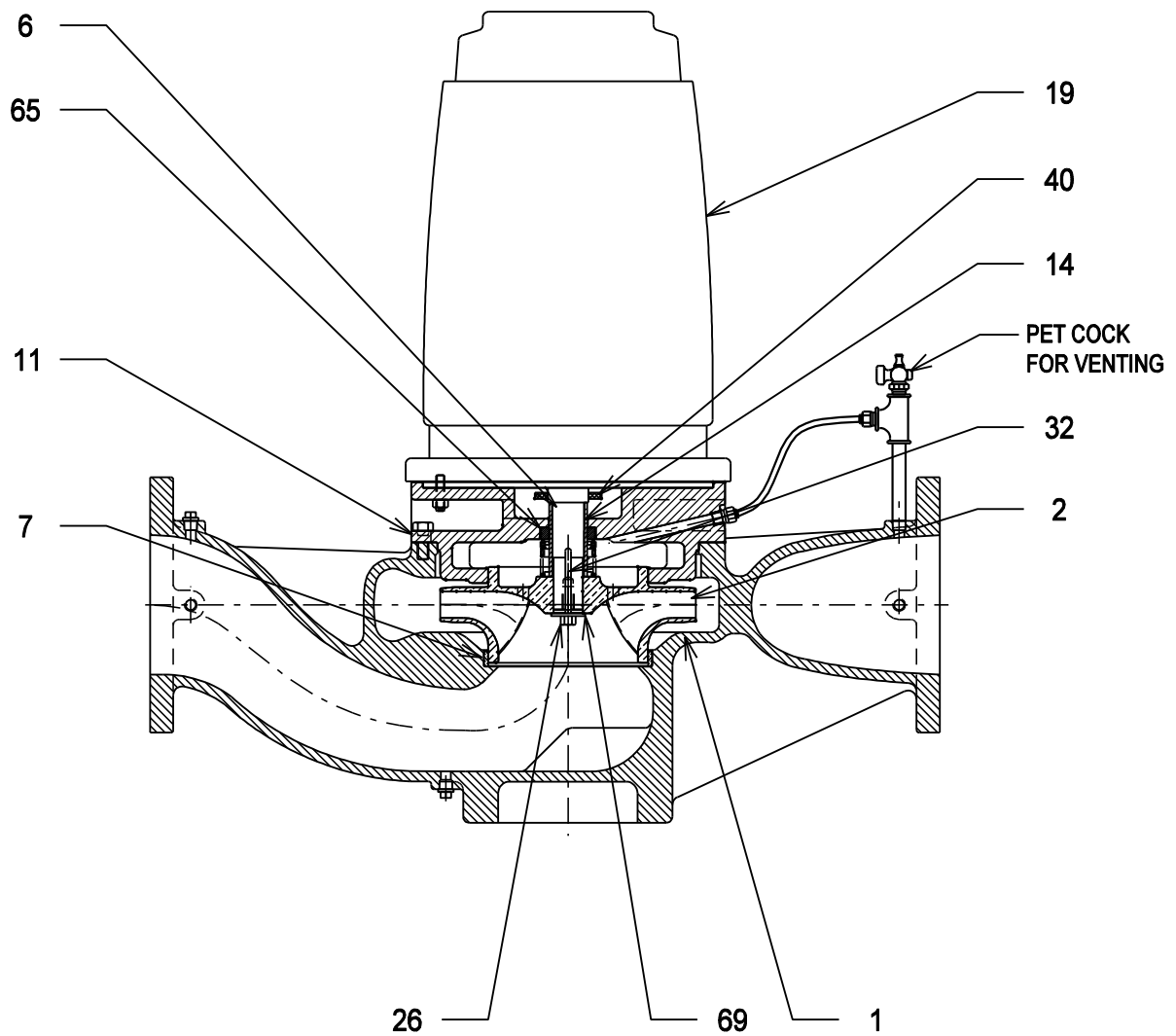

## Typical Assembly Section, Type VIL-CC

ITEM	DESCRIPTION	MATERIAL	ITEM	DESCRIPTION	MATERIAL
1	CASING	Cast Iron - ASTM A48-CL30	19	MOTOR	Mfg. Std.
2	IMPELLER	Bronze - ASTM B584-875	26	IMPELLER SCREW	Stainless Steel - Type 304
6	MOTOR SHAFT	Steel	32	IMPELLER KEY	Stainless Steel - ASTM Type 304
7	CASING RING	Bronze - ASTM B505-932	40	DEFLECTOR	Nitrile
11	VOLUTE COVER	Cast Iron - ASTM A48-CL30	65	MECHANICAL SEAL	316 S.S. / Carbon VS. Silicon Carbide
14	SHAFT SLEEVE	Bronze - ASTM B505-932	65	MECHANICAL SEAL (OPTIONAL)	316 S.S. / Tungsten Carbide VS. Tungsten Carbide
14	SHAFT SLEEVE (OPTIONAL)	416 S.S.	69	IMPELLER WASHER	Stainless Steel AISI 416

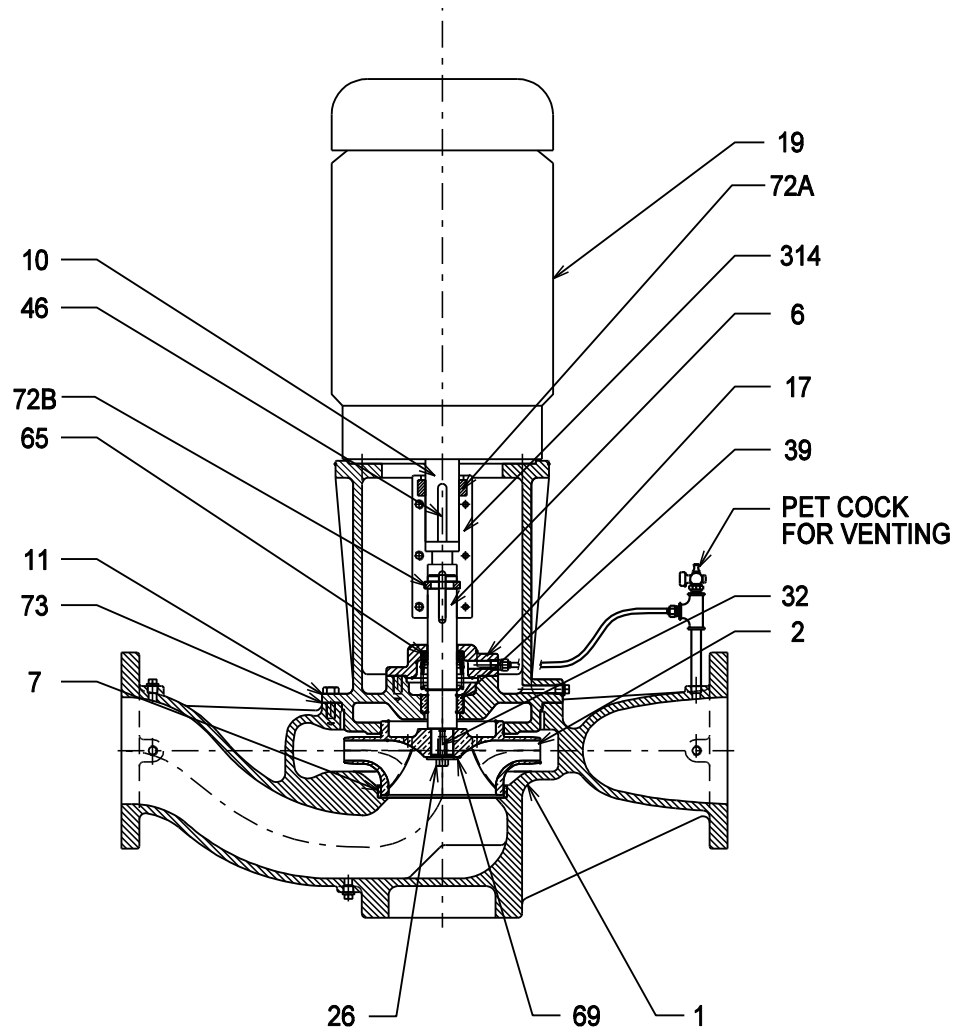

## Typical Assembly Section, Type VIL-RC (Frames 286 and smaller)

ITEM	DESCRIPTION	MATERIAL	ITEM	DESCRIPTION	MATERIAL
1	CASING	Cast Iron - ASTM A48-CL30 (See Note 1)	39	THROTTLE BUSHING	Graphalloy GM 205.3
2	IMPELLER	Bronze - ASTM B584-875	46	COUPLING KEY	Steel - ASTM A108-1018
6	PUMP SHAFT	416 S.S.	65	MECHANICAL SEAL	316 S.S. / Carbon VS. Silicon Carbide
7	CASING RING	Bronze - ASTM B505-932	65	MECHANICAL SEAL (OPTIONAL)	316 S.S. / Tungsten Carbide VS. Tungsten Carbide
10	MOTOR SHAFT	Steel	69	IMPELLER WASHER	Stainless Steel AISI 416
11	VOLUTE COVER	Cast Iron - ASTM A48-CL30	72A	COLLAR	Mfg. Std. Steel
17	GLAND	Cast Iron - ASTM A48-CL30	72B	SPLIT COLLAR	Mfg. Std. Steel
19	MOTOR	Mfg. Std.	73	GASKET	Vellumoid
26	IMPELLER SCREW	Stainless Steel - Type 304	314	Rigid Coupling	High Tensile Aluminum
32	IMPELLER KEY	Stainless Steel - ASTM Type 304			

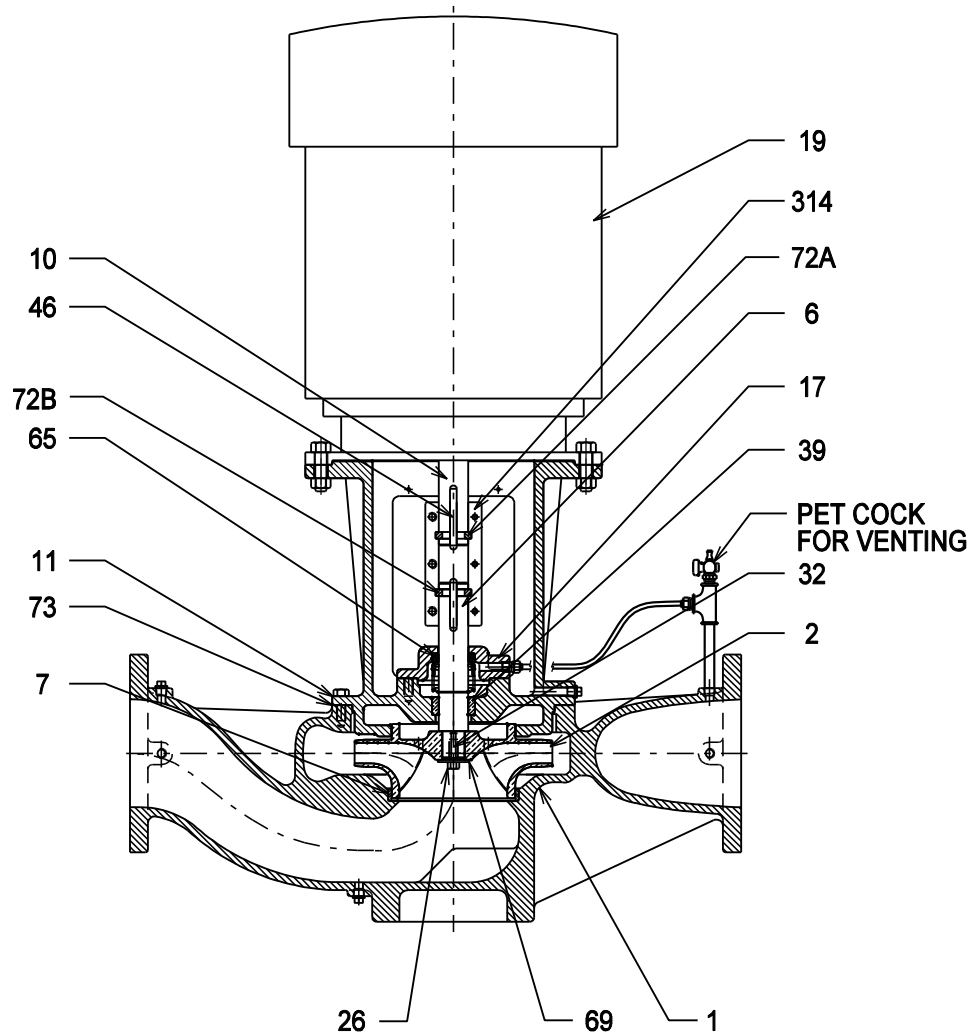

## Typical Assembly Section, Type VIL-RC (Frames 324 and larger)

ITEM	DESCRIPTION	MATERIAL	ITEM	DESCRIPTION	MATERIAL
1	CASING	Cast Iron - ASTM A48-CL30 (See Note 1)	39	THROTTLE BUSHING	Graphalloy GM 205.3
2	IMPELLER	Bronze - ASTM B584-875	46	COUPLING KEY	Steel - ASTM A108-1018
6	PUMP SHAFT	416 S.S.	65	MECHANICAL SEAL	316 S.S. / Carbon VS. Silicon Carbide
7	CASING RING	Bronze - ASTM B505-932	65	MECHANICAL SEAL (OPTIONAL)	316 S.S. / Tungsten Carbide VS. Tungsten Carbide
10	MOTOR SHAFT	Steel	69	IMPELLER WASHER	Stainless Steel AISI 416
11	VOLUTE COVER	Cast Iron - ASTM A48-CL30	72A	SPLIT COLLAR	Mfg. Std. Steel
17	GLAND	Cast Iron - ASTM A48-CL30	72B	SPLIT COLLAR	Mfg. Std. Steel
19	MOTOR	Mfg. Std.	73	GASKET	Vellumoid
26	IMPELLER SCREW	Stainless Steel - Type 304	314	Rigid Coupling	High Tensile Aluminum
32	IMPELLER KEY	Stainless Steel - ASTM Type 304			

Note 1: The following pumps have an optional casing material ASTM A536 Grade 65-45-12 Ductile Iron V10A15A-RC

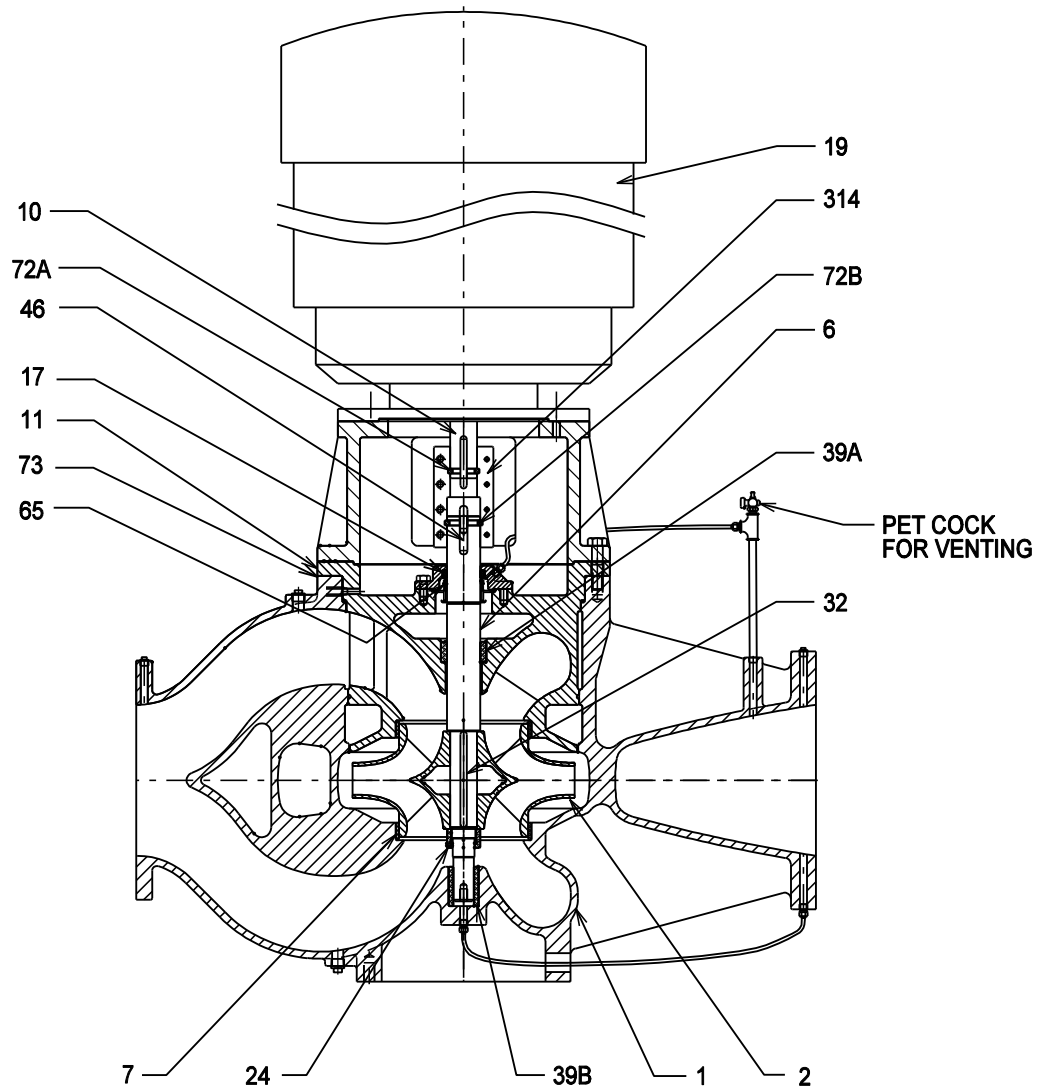

## Typical Assembly Section, Type VIL-DS

ITEM	DESCRIPTION	MATERIAL	ITEM	DESCRIPTION	MATERIAL
1	CASING	Cast Iron - ASTM A48-CL30	32	IMPELLER KEY	Stainless Steel - ASTM Type 304
	CASING (Optional)	Ductile Iron - ASTM A536 Grade 65-45-12	39A	THROTTLE BUSHING	Graphalloy GM 205.3
2	IMPELLER	Bronze - ASTM B584-875	39B	LOWER BUSHING	Graphalloy GM 205.3
6	PUMP SHAFT	416 S.S.	46	COUPLING KEY	Steel - ASTM A108-1018
7	CASING RING	Bronze - ASTM B505-932	65	MECHANICAL SEAL	316 S.S. / Carbon VS. Silicon Carbide
10	MOTOR SHAFT	Steel	65	MECHANICAL SEAL (OPTIONAL)	316 S.S. / Tungsten Carbide VS. Tungsten Carbide
11	VOLUTE COVER	Cast Iron - ASTM A48-CL30	72A	SPLIT COLLAR	Mfg. Std. Steel
17	GLAND	Cast Iron - ASTM A48-CL30	72B	SPLIT COLLAR	Mfg. Std. Steel
19	MOTOR	Mfg. Std.	73	GASKET	Vellumoid
24	IMPELLER NUT	ASTM B16 C36000 Bronze	314	RIGID COUPLING	High Tensile Aluminum

# Shaft Collar Settings for Type VIL-RC Pumps (Frames 286 and smaller)

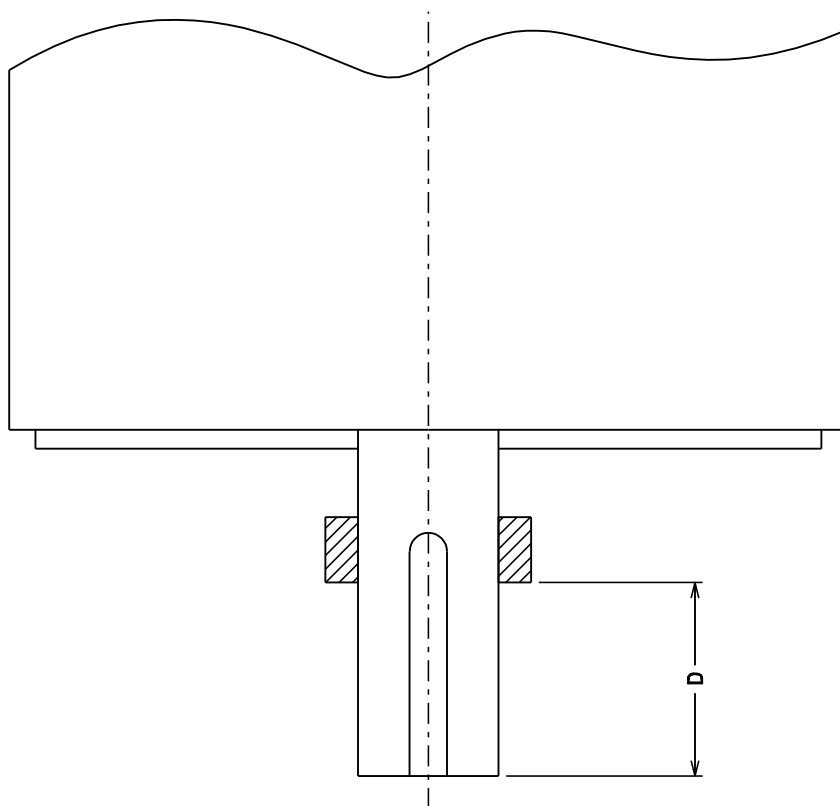

MOTOR FRAME	D
184 - 186 TC	1 1/4"
213 - 215 TC	1 27/32"
254 - 256 TC	2 5/16"
284 - 286 TC	2 5/8"

## Notes